

Hack10 Clevis Self Locking Hook

The Hack10 clevis self locking hook incorporates a special latch mechanism that locks itself automatically when it comes under load. Manual interaction of the latch trigger then allows disengagement of the locking mechanism once the load is relieved. This hook is capable of attachment directly onto chain thanks to its clevis attachment type. Manufactured from alloy steel, the Hack10 clevis self locking hook is 25% stronger than a grade 8 equivalent, delivering a greater working load limit without the need for a larger diameter chain sling.

Standards: designed and manufactured in accordance with EN1677-1, ASTM A952/A952M, and DIN PAS 1061 and suitable for use in chain slings certified to EN818-4.

Product sizes: available for chain sizes from 6mm to 22mm and with working load limits from 1.4 tonnes to 19.0 tonnes.

Temperature: operational temperature range of - 40°C to + 200°C without reduction in working load limit.

Material: alloy steel.

Testing: crack detection following heat treatment, and proof load tested to 2.5 times working load limit.

Safety factor: 4 : 1.

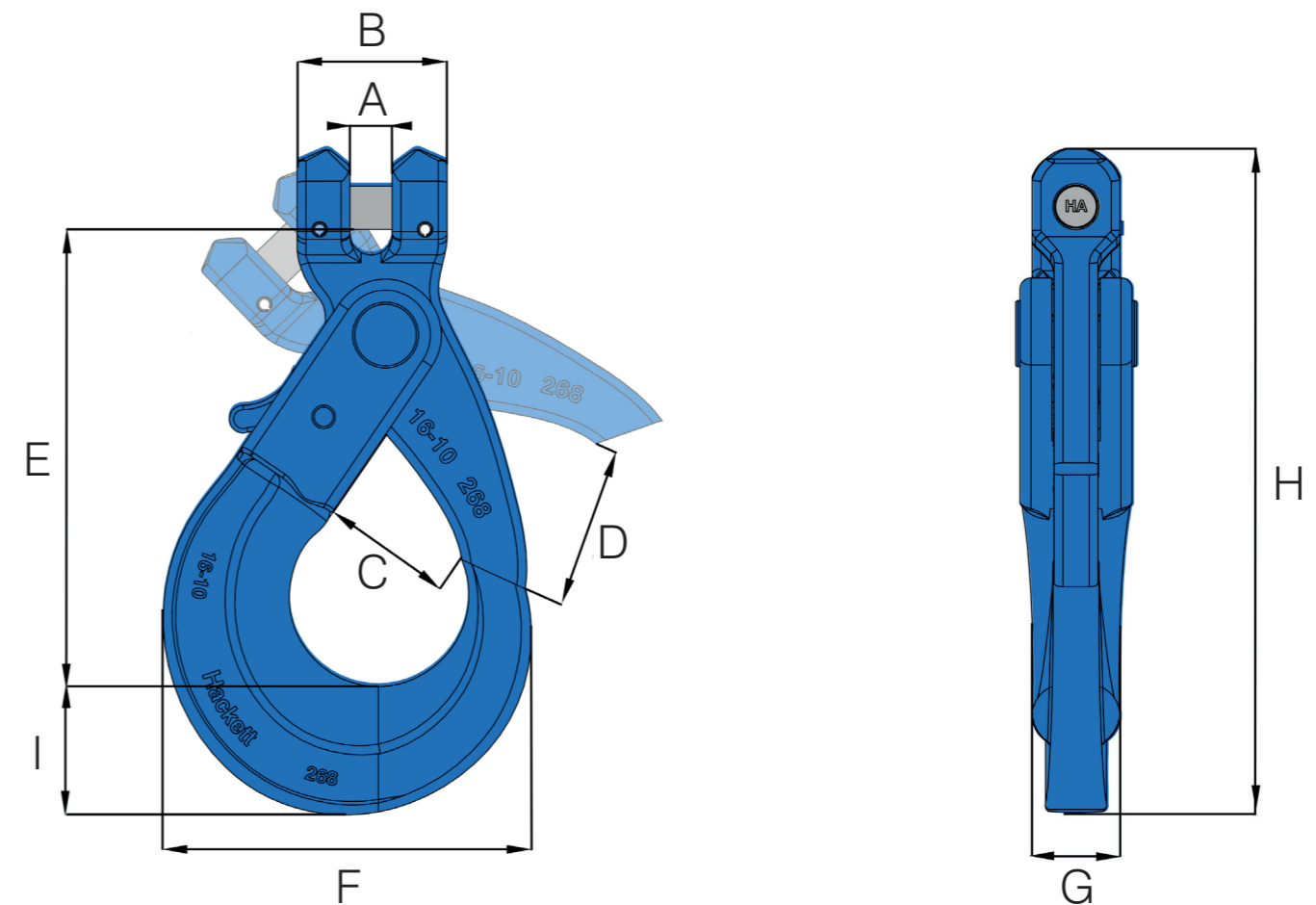

Specifications

Part Code	Chain Size mm	A mm	B mm	C mm	D mm	E mm	F mm	G mm	H mm	I mm	Box Qty.	WLL tonnes	Mass kg
10-H05-06	6	8.0	32.0	28.0	31.5	96.0	73.0	15.0	131.0	21.0	40	1.4	0.50
10-H05-08	8	9.5	36.0	36.0	40.0	121.0	90.0	20.0	163.0	27.0	20	2.5	0.90
10-H05-10	10	12.0	46.0	45.0	46.0	144.0	108.0	26.0	194.0	30.0	15	4.0	1.45
10-H05-13	13	15.0	59.0	53.6	66.0	182.0	137.0	32.5	251.0	41.0	6	6.7	2.90
10-H05-16	16	18.5	70.0	61.0	75.0	220.0	168.0	38.0	303.0	51.0	4	10.0	5.50
10-H05-20	20	25.0	85.0	76.5	80.0	235.0	190.0	50.0	337.0	64.0	2	16.0	8.60
10-H05-22	22	25.5	98.0	76.0	104.6	271.0	202.0	52.0	386.0	67.0	2	19.0	12.10

Hack10 Clevis Self Locking Hook

The Hack10 clevis self locking hook incorporates a special latch mechanism that locks itself automatically when it comes under load. Manual interaction of the latch trigger then allows disengagement of the locking mechanism once the load is relieved. This hook is capable of attachment directly onto chain thanks to its clevis attachment type. Manufactured from alloy steel, the Hack10 clevis self locking hook is 25% stronger than a grade 8 equivalent, delivering a greater working load limit without the need for a larger diameter chain sling.

Standards: designed and manufactured in accordance with EN1677-1, ASTM A952/A952M, and DIN PAS 1061 and suitable for use in chain slings certified to EN818-4.

Product sizes: available for chain sizes from 7/32 inch to 7/8 inch and with working load limits from 3,200 lbs to 42,700 lbs.

Temperature: operational temperature range of - 40°C to + 200°C without reduction in working load limit.

Material: alloy steel.

Testing: crack detection following heat treatment, and proof load tested to 2.5 times working load limit.

Safety factor: 4 : 1.

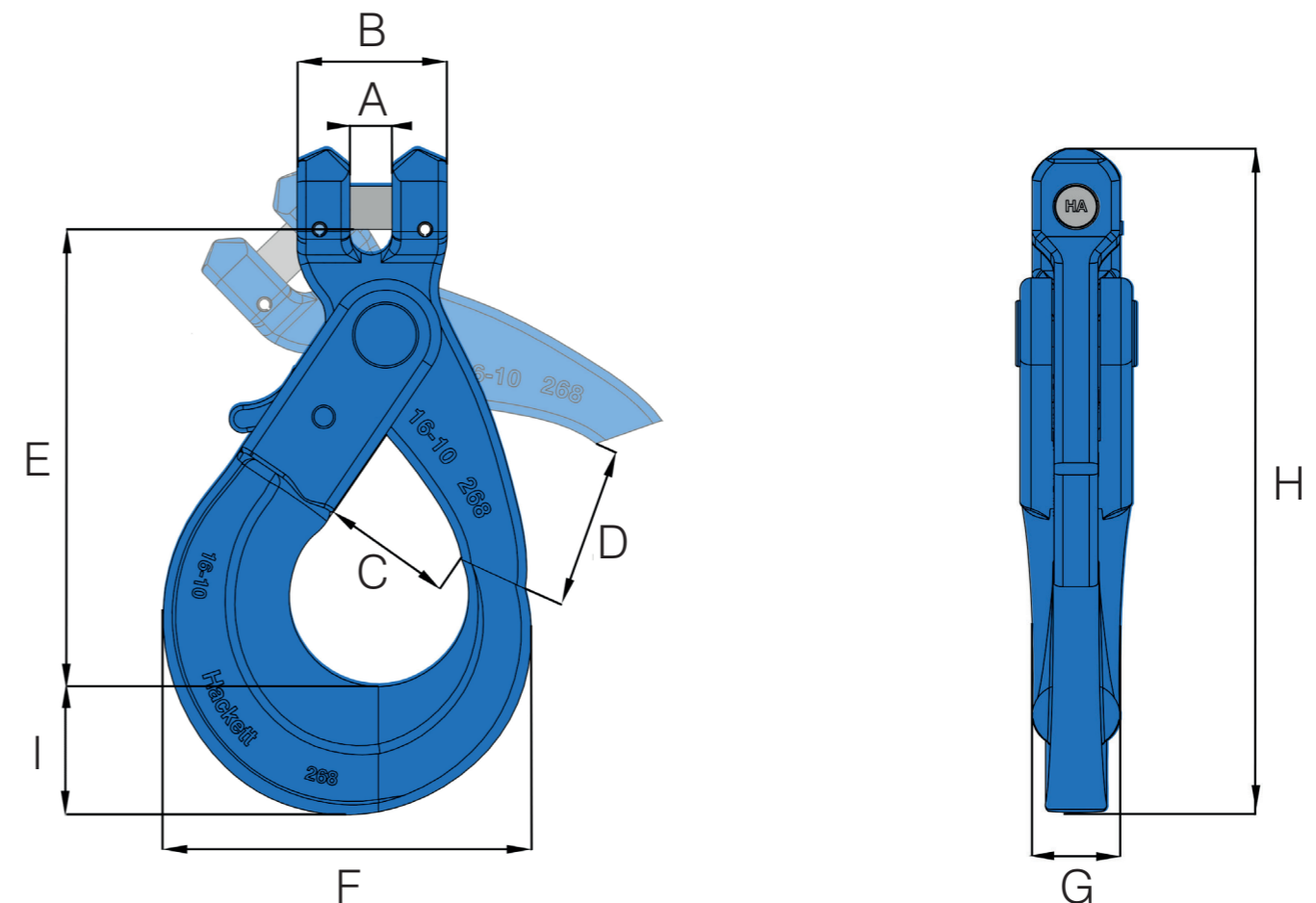

Specifications

Part Code	Chain Size inch	A inch	B inch	C inch	D inch	E inch	F inch	G inch	H inch	I inch	Box Qty.	WLL lbs	Mass lbs
10-H05-06	7/32	0.31	1.26	1.10	1.24	3.78	2.87	0.59	5.16	0.83	40	3200	1.10
10-H05-08	5/16	0.37	1.42	1.42	1.57	4.76	3.54	0.79	6.42	1.06	20	5700	1.98
10-H05-10	3/8	0.47	1.81	1.77	1.81	5.67	4.25	1.02	7.64	1.18	15	8800	3.20
10-H05-13	1/2	0.59	2.32	2.11	2.60	7.17	5.39	1.28	9.88	1.61	6	15000	6.39
10-H05-16	5/8	0.73	2.76	2.40	2.95	8.66	6.61	1.50	11.93	2.01	4	22600	12.13
10-H05-20	3/4	0.98	3.35	3.01	3.15	9.25	7.48	1.97	13.27	2.52	2	35300	18.96
10-H05-22	7/8	1.00	3.86	2.99	4.12	10.67	7.95	2.05	15.20	2.64	2	42700	26.68